

# Lifting column



technology<sup>?</sup>

**X-series**

X13

X23

Max 10.000 N





## Description

The X13 and X23-columns are the most robust columns in the industry. It is extremely stable with offset loads and suits demanding applications. With its extremely stiff aluminum tubes and long-life pads, it offers a stable and reliable guiding system that is maintenance free.



### Features

-  Long lifetime
-  Extreme offset capacity
-  Extremely robust

- Push
- Build in hall sensors
- Cable out small tube (SX-A)
- Cable out large tube (SX-E, SX-F, SX-S)
- Limit switch

### Options

- Pull
- Potentiometer
- Cable out large tube (SX-A)
- Cable out small tube (SX-E, SX-F, SX-S)
- Cable through
- Customizable top/bottom plates

## Technical data

	SX-AF13 SX-AF23	SX-AM13 SX-AM23	SX-SF13 SX-SF23	SX-AO13 SX-AO23	SX-AE13 SX-AE23	SX-EF13 SX-EF23	SX-SD13 SX-SD23
Force, max push*	1.000 N	1.500 N	1.750 N	2.000 N		2.250 N	
Self-locking force**	2.500 N	2.500 N	1.000 N	2.500 N		1.200 N	1.750 N
Speed @max load	45 mm/s	38 mm/s	21 mm/s	30 mm/s	24 mm/s	32 mm/s	16 mm/s
Stroke, S (longer strokes on request)	700 mm			1.000 mm	800 mm	700 mm	
Retracted length, R***	SX-AF13: R=S+60mm SX-AF23: R=S+120mm	SX-AM13: R=S+70mm SX-AM23: R=S+120mm	R=S+120 mm	SX-AO13: R=S+70mm SX-AO23: R=S+120mm	SX-AE13: R=S+60mm SX-AE23: R=S+120mm	R=S+120 mm	
Duty cycle [%]	10 % (1 min ON / 9 min OFF)						
Voltage	24 VDC						
Ambient temp	+10°C to +40°C						
Current @max load	8 A		5,5 A	8 A		10 A	5,5 A
IP Class	IP 30						
Safety factor Static centric load @ max stroke & load*	7	5	4	5	4	3	1,2

\* See diagrams on page 4-5

\*\* Only applied when connected by short circuit

\*\*\* Longer retracted length enables more offset load, see diagrams on page 4-5

## Technical data

	SX-ED13 SX-ED23	SX-AB13 SX-AB23	SX-SE13 SX-SE23	SX-EE13 SX-EE23	SX-AP13 SX-AP23	SX-AN13 SX-AN23	SX-FE13 SX-FE23	SX-EA13 SX-EA23
Force, max push*	2.750 N	2.800 N	3.000 N	3.500 N	4.000 N	5.000 N	6.000 N	10.000 N
Self-locking force**	1.500 N	3.000 N	2.750 N	1.500 N	5.000 N	6.000 N	6.000 N	10.000 N
Speed @max load	24 mm/s	12 mm/s	10 mm/s	16 mm/s	15 mm/s	12 mm/s	8 mm/s	6 mm/s
Stroke, S (longer strokes on request)	500 mm	800 mm	700 mm		1.000 mm	700 mm		500 mm
Retracted length, R***	$R = S + 120 \text{ mm}$	SX-AB13: $R=S+60\text{mm}$ SX-AB23: $R=S+120\text{mm}$	$R = S + 120 \text{ mm}$		SX-AP13 / SX-AN13: $R=S+70 \text{ mm}$ SX-AP23 / SX-AN23: $R=S+120 \text{ mm}$		$R = S + 120 \text{ mm}$	
Duty cycle [%]	10% (1 min ON / 9 min OFF)							
Voltage	24 VDC							
Ambient temp	+10°C to +40°C							
Current @max load	10 A	8 A	5,5 A	10 A	8 A		10 A	15 A
IP Class	IP 30							
Safety factor Static centric load @ max stroke & load*	1,8	2,5	3,5	3	2,5	1,8	1,5	1,8

### Technical drawing X13

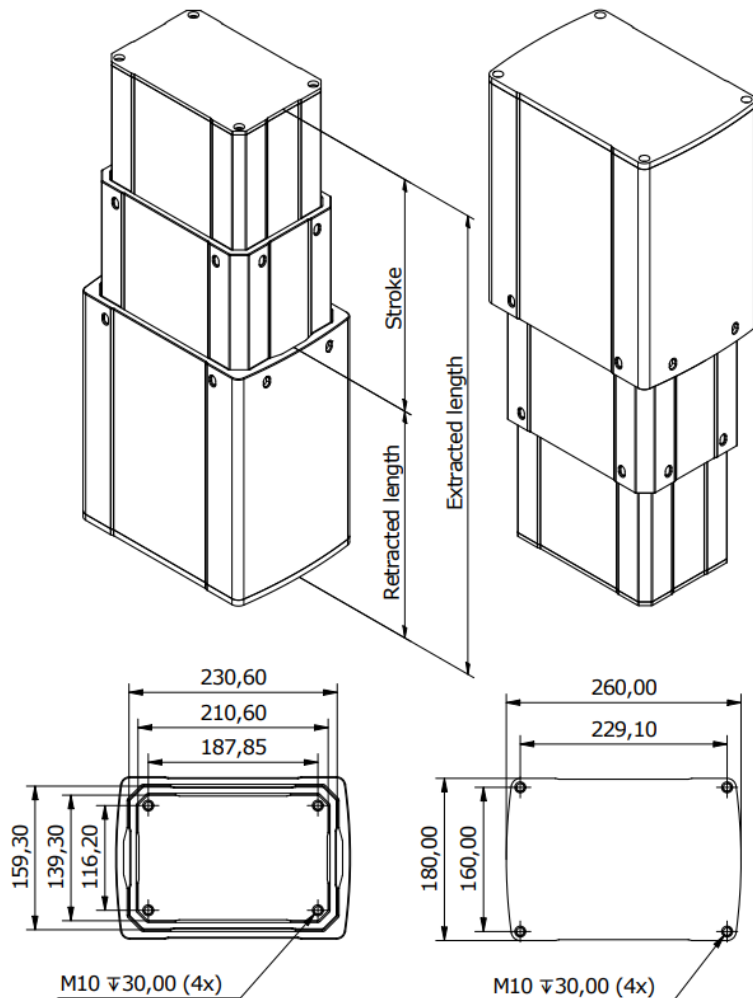

### Technical drawing X23

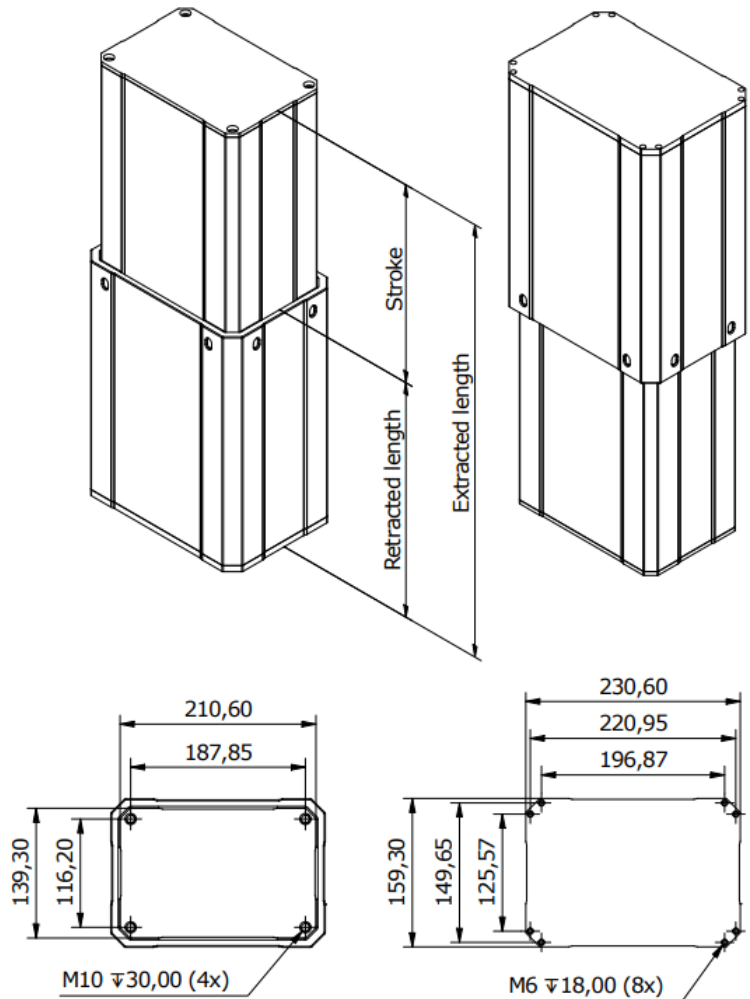

### Pin layout (SX-A / SX-E / SX-F)

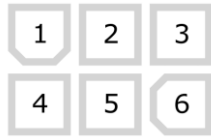

6 pin 172160-1 Male

### Connectors

	Description	Colour
1.	Motor -	Black
2.	Motor +	Blue
3.	Hall sensor +5V,	Red
4.	Hall sensor output 2	Violet
5.	Hall sensor -	Black
6.	Hall sensor output 1	Green

### Pin layout (SX-S)



8 pin JS-1149-08 Male

### Connectors

	Description	Colour
1.	Hall sensor 1	White
2.	+5V	Red
3.	Limit switch 2 (NC)	-
4.	Motor+	Green (motor: White)
5.	Hall sensor 2	Blue
6.	Limit switch 1 (NC)	-
7.	GND	Black
8.	Motor-	Yellow

## Diagrams (Up to 2 250N)

### Offset load

Long retracted length,  $R = \text{Stroke} + 270 \text{ mm}$

Short retracted length,  $R = \text{Stroke} + 195 \text{ mm}$

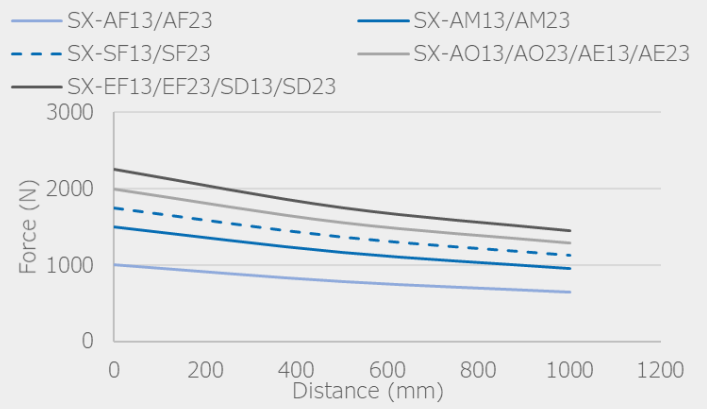
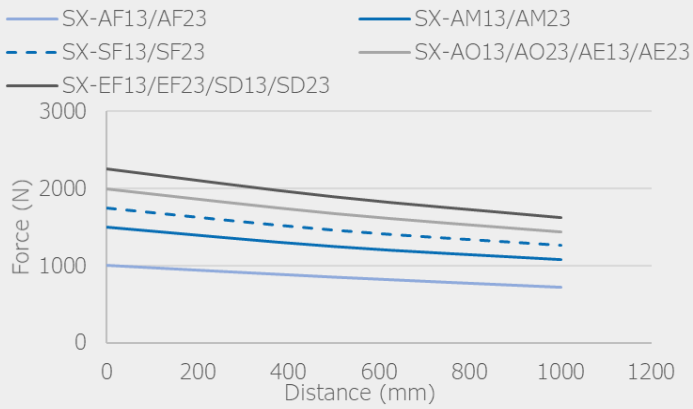

### Safety factor

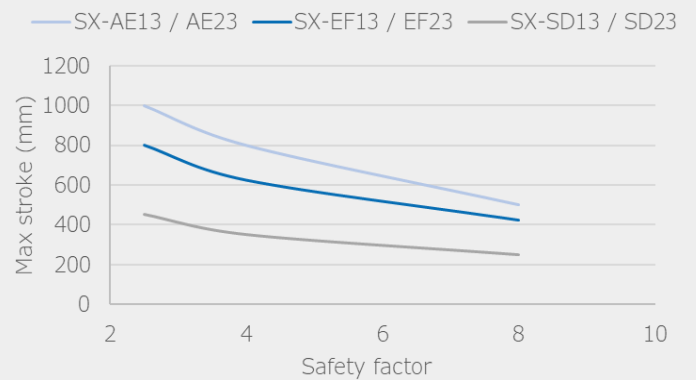
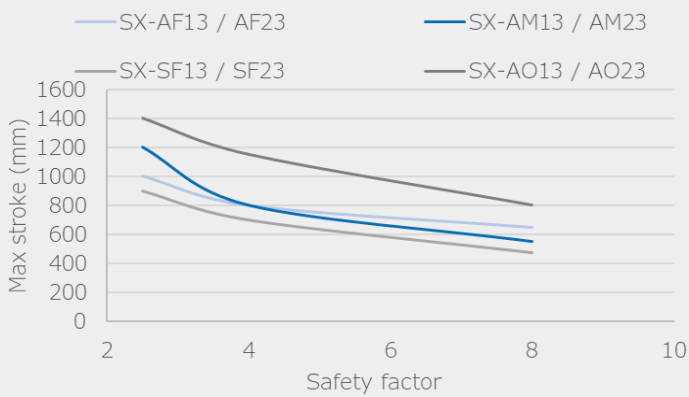

### Speed

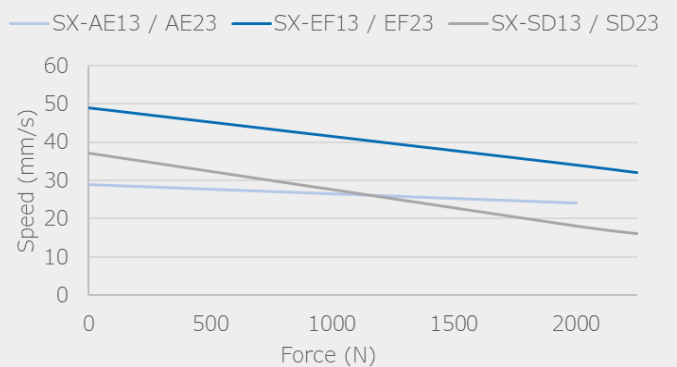
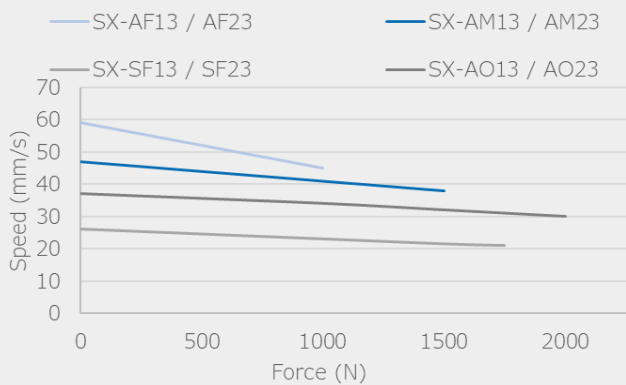

## Diagrams (From 2 750N to 10 000N)

### Offset load

Long retracted length,  $R = \text{Stroke} + 270 \text{ mm}$

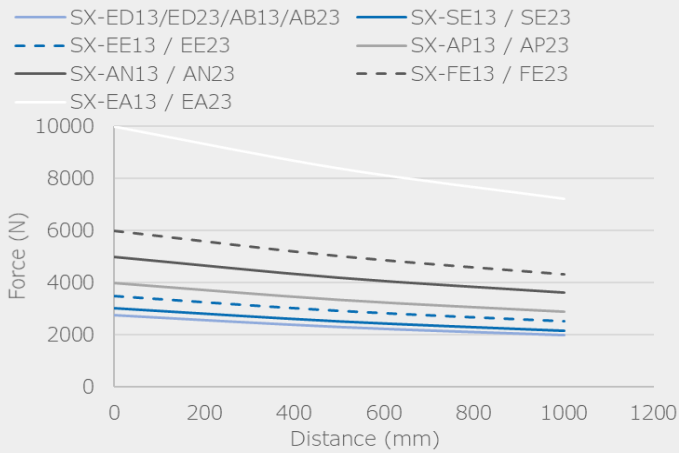

Short retracted length,  $R = \text{Stroke} + 195 \text{ mm}$

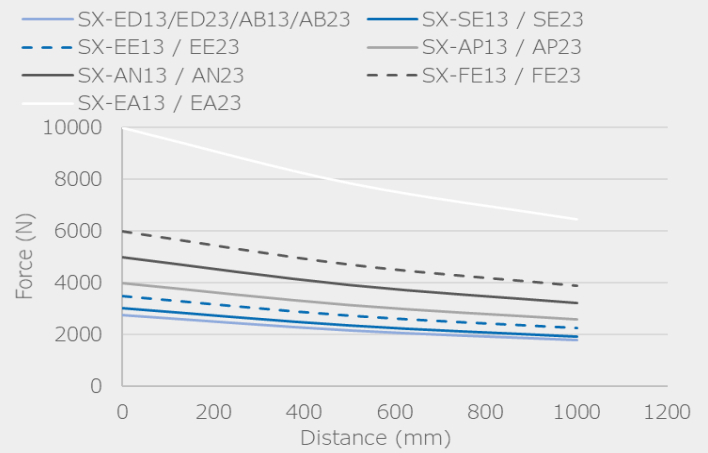

### Safety factor

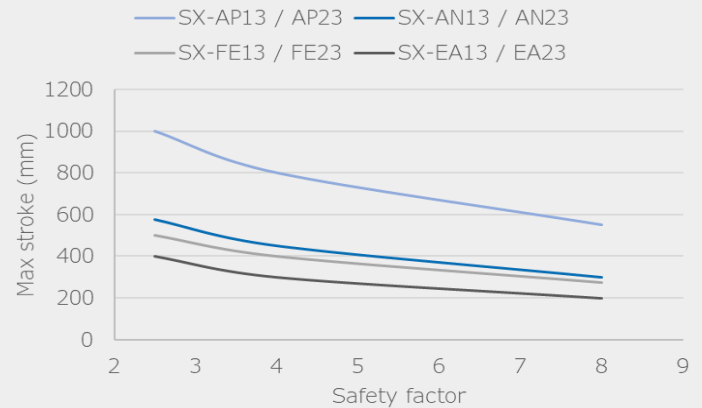
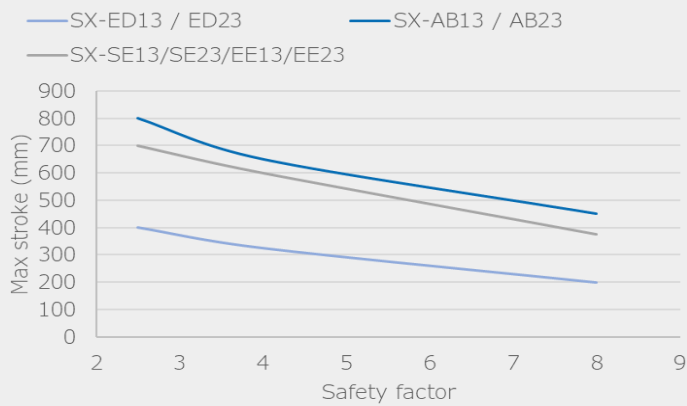

### Speed

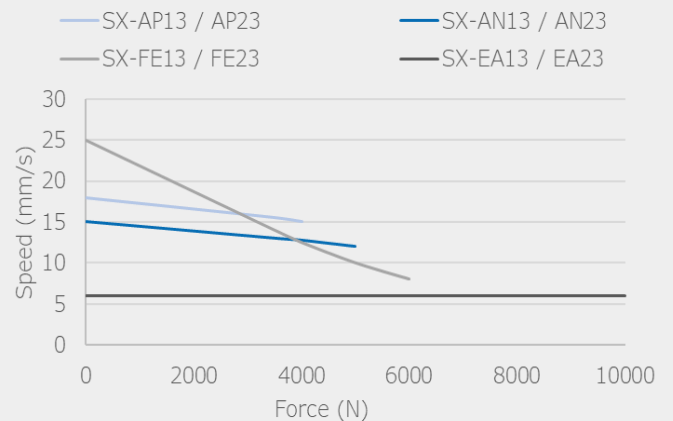
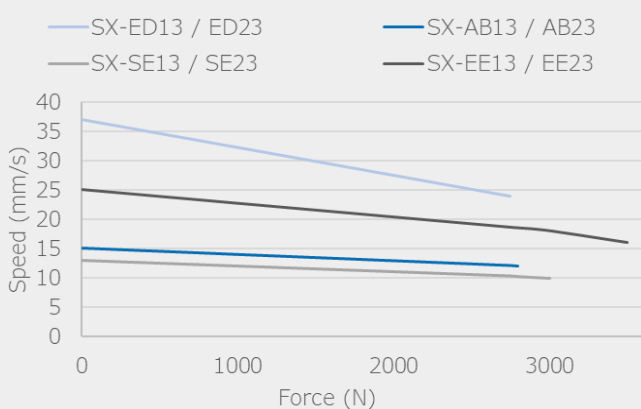

# X2 Technology – The Customizer

Before use of products, see general terms & conditions and operating manuals. Lifetime and suitability are depending on application and must therefore be tested by each user. Specifications subject to change without prior notice. All components in this datasheet are property of X2 Technology and may therefore not be used without permission.

Copyright © X2 Technology 2021.04.

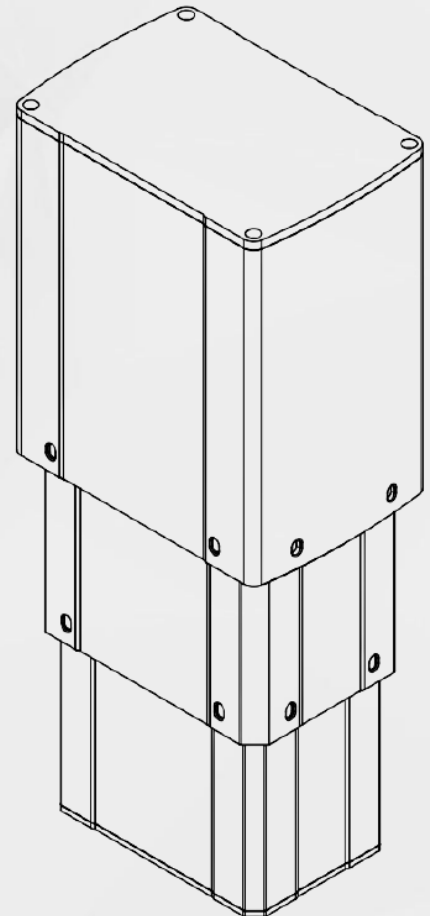

technology

## X2 Technology AB



+46 470 717950



info@x2technology.se



www.x2technology.se



Made in Sweden