

Product range catalogue



technology⁷

Columns



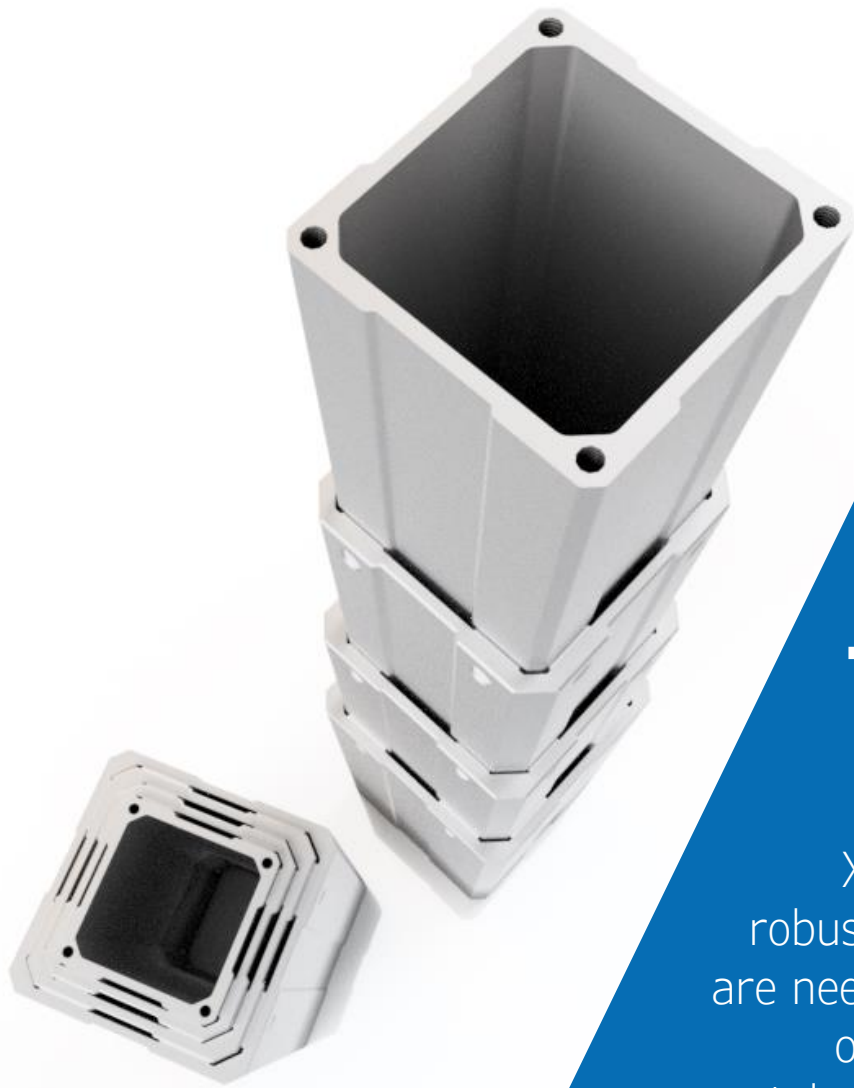

The Customizer

X2 Columns are used wherever robust and reliable guiding systems are needed to lift medical, ergonomic or industrial equipment. In this catalogue, you can find our standard range of columns. If you cannot find any that fulfils your needs, we can make a customized solution for you. In fact, most of our supplied lifting columns are customized.

Table of content

RANGE OF COLUMNS	3
COMPARISON	4
A-SERIES	5
B-SERIES	6
E-SERIES	7
F-SERIES	8
G-SERIES	9
X-SERIES	10

Range of columns

All our columns are made off stiff aluminium tubes and treated for lowest possible friction. This enables us to mount them with very tight tolerances to achieve maintenance free and smooth run without any play. Our columns are applicable on the medical, ergonomic and industrial area. Below you can see the standard range with a maximum stroke of 5.000 mm.

A-series

The A-series is our square model that consists of 2 to 6 sections with various sizes. It has a very stable performance and works great with heavy centric and offset loads.

B-series

The B-series is one of our rectangular models in the middle range that enables a very stable and smooth run even with high offset loads.



A-series



B-series



E-series



F-series

E-series

E-series is our smallest series. It offers good stability and performance for applications in confined spaces or for lighter loads.

F-series

F-series is our asymmetric tube which has a softer design yet still the same good qualities that the other tubes have when it comes to performance.

G-series

G-series lays in the small range of the rectangular models. It is a very robust and reliable tubes and works good with offset loads.

X-series

The X-series is our top of the range tube and the most robust tube on the market. It performs exceptionally well with extreme offset loads.



G-series



X-series

Comparison

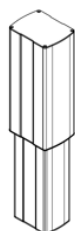

E-series

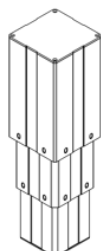

A-series

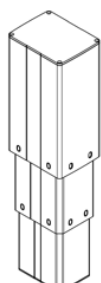

G-series

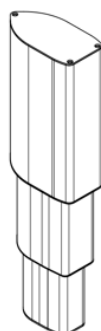

F-series

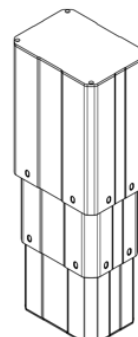

B-series

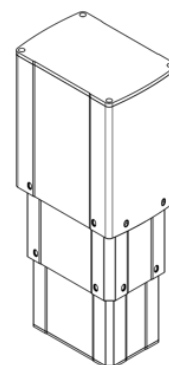

X-series

Dimensions

Section 1

Section 2

Section 3

Section 4

Section 5

Section 6

	Section 1	Section 2	Section 3	Section 4	Section 5	Section 6
Serie A	163x163 mm	146x146 mm	129x129 mm	113x113 mm	96x96 mm	83x83 mm
Serie B	219,2x157,2 mm	205,9x143,9 mm	192x130 mm	x	x	x
Serie E	133,6x103 mm	115,8x85 mm	x	x	x	x
Serie F	187,7x98 mm	154,4x83 mm	125x66 mm	x	x	x
Serie G	163x127 mm	147,7x114,7 mm	135,4x102,4 mm	x	x	x
Serie X	260x180 mm	230,6x159,3 mm	210,6x139,3 mm	x	x	x

A-series



Features

Very robust
Great offset load capacity
Long stroke
Long lifetime
Extremely low friction

Options

Outer tube on top/bottom
From 2 to 6 sections
With or without top/bottom plates
Customized

Section	Dimensions (mm)	Weight (kg/m)
1	163x163	11,4
2	146x146	9,3
3	129x129	8,3
4	113x113	6,1
5	96x96	5,2
6	83x83	4,1

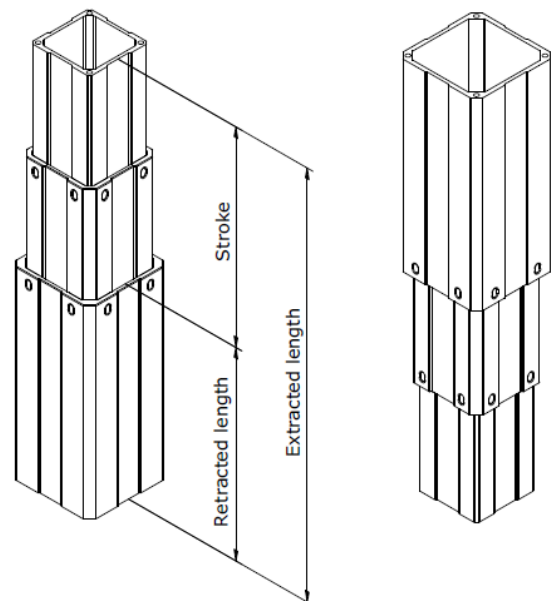



Features

- Very stable
- Great offset load capacity
- Long lifetime
- Extremely low friction
- Low noise level

Options

- Outer tube on top/bottom
- From 2 to 3 sections
- With or without top/bottom plates
- Customized

Section	Dimensions (mm)	Weight (kg/m)
1	219,20x157,19	11
2	205,90x143,90	8,8
3	192,00x130,00	8,9

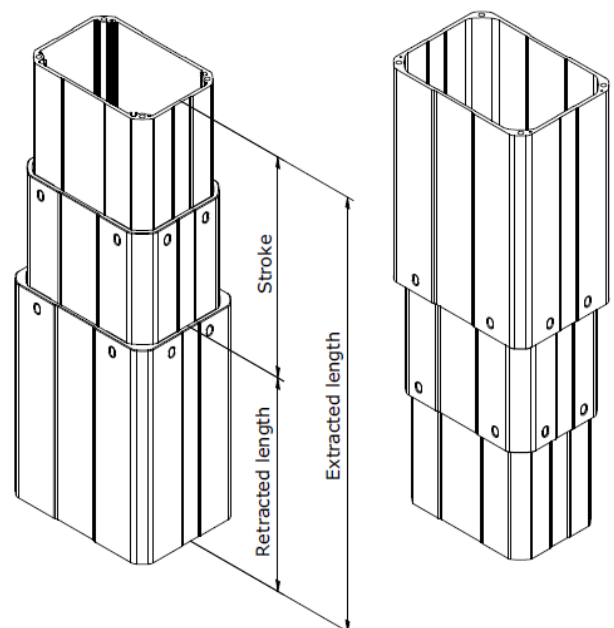



Features

Very stable
 2 sections
 Long lifetime
 Extremely low friction
 Small

Options

With or without top/bottom plates
 Outer tube on top/bottom
 Customized

Section	Dimensions (mm)	Weight (kg/m)
1	133,61x103,00	5,4
2	115,76x85,00	4,2

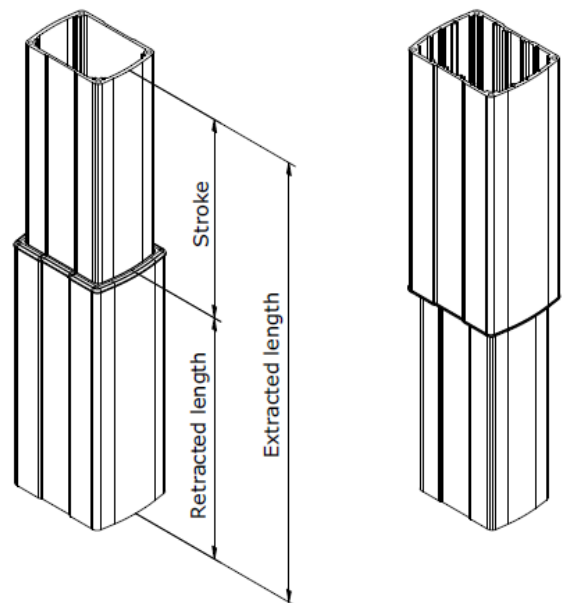

F-series



Features

Asymmetric design
Long lifetime
Extremely low friction

Options

Outer tube on top/bottom
From 2 to 3 sections
With or without top/bottom plates
Customized

Section	Dimensions (mm)	Weight (kg/m)
1	187,7x98,00	8,5
2	154,35x83,00	6,5
3	125,00x66,00	5,2

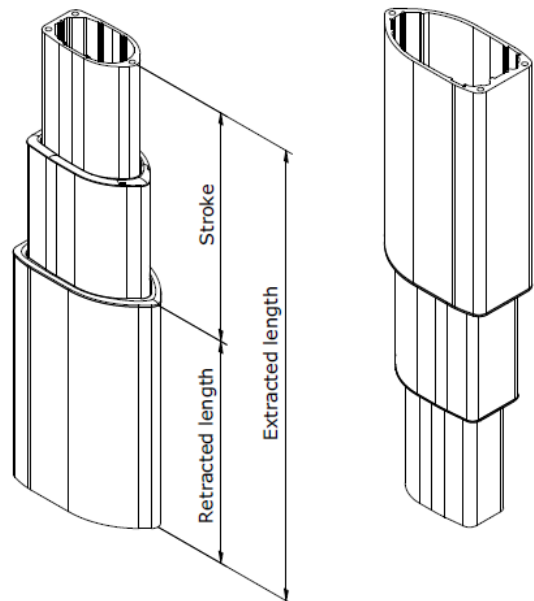



Features

Very robust
 Good offset load capacity
 Long lifetime
 Extremely low friction
 Small size

Options

Outer tube on top/bottom
 From 2 to 3 sections
 With or without top/bottom plates
 Customized

Section	Dimensions (mm)	Weight (kg/m)
1	163,00x127,00	8
2	147,70x114,70	6,1
3	135,40x102,40	6,0

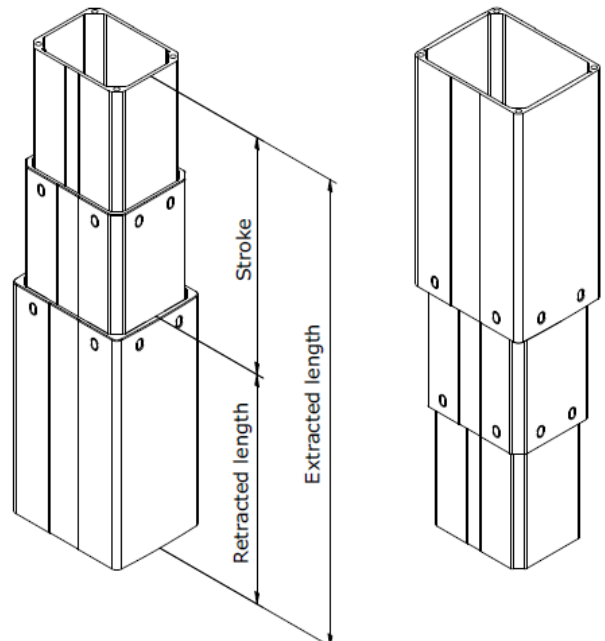



Features

- Extremely robust
- Extreme offset load capacity
- Long lifetime
- Extremely low friction

Options

- Outer tube on top/bottom
- From 2 to 3 sections
- With or without top/bottom plates
- Customized

Section	Dimensions (mm)	Weight (kg/m)
1	260,00x180,00	20,1
2	230,60x159,30	14,7
3	210,60x139,30	14,3

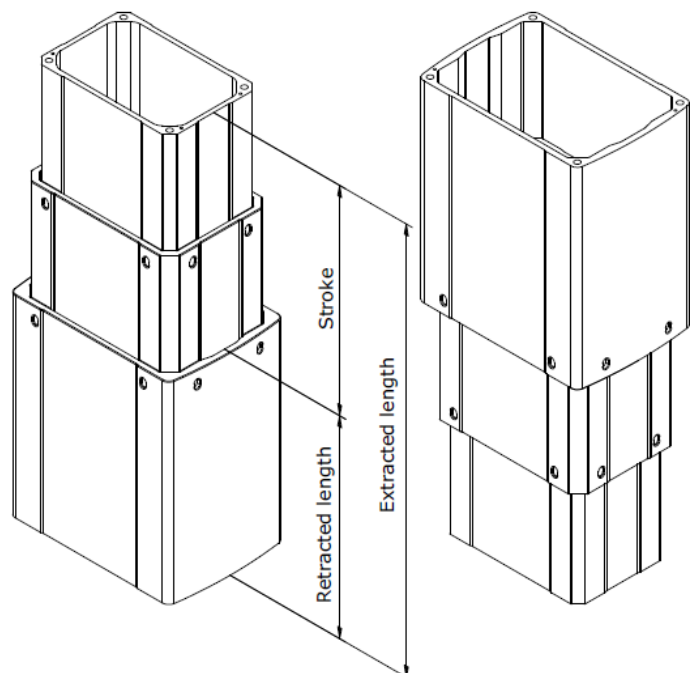

X2 Technology – The Customizer

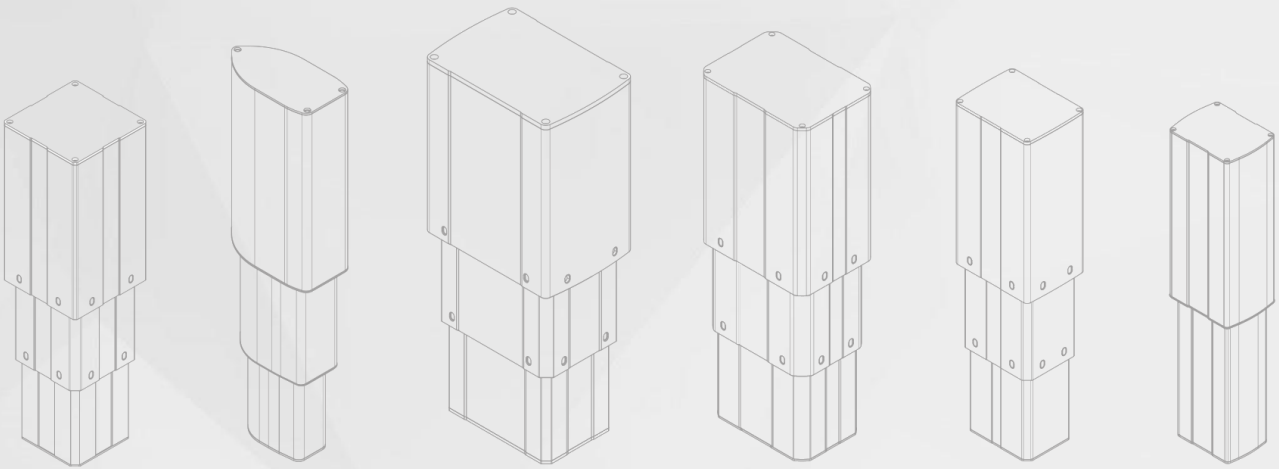

About us

X2 Technology is a Swedish company that manufactures top range lifting columns to the medical, ergonomic and industrial market. Our biggest strength lays in our exceptional experience of guided aluminum profiles. The experience enables us to develop and design innovative products in close cooperation with our customers to meet individual requirements. With our flexible manufacturing techniques, we can produce both small and big quantities of customized products.

Before use of products, see general terms & conditions and operating manuals. Lifetime and suitability are depending on application and must therefore be tested by each user. Specifications subject to change without prior notice. All components in this datasheet are property of X2 Technology and may therefore not be used without permission.
Copyright © X2 Technology 2021.04.



X2 Technology AB



+46 470 717950



info@x2technology.se



www.x2technology.se