



X2 TECHNOLOGY

A Phoenix Mecano Brand

Accessories

Battery pack

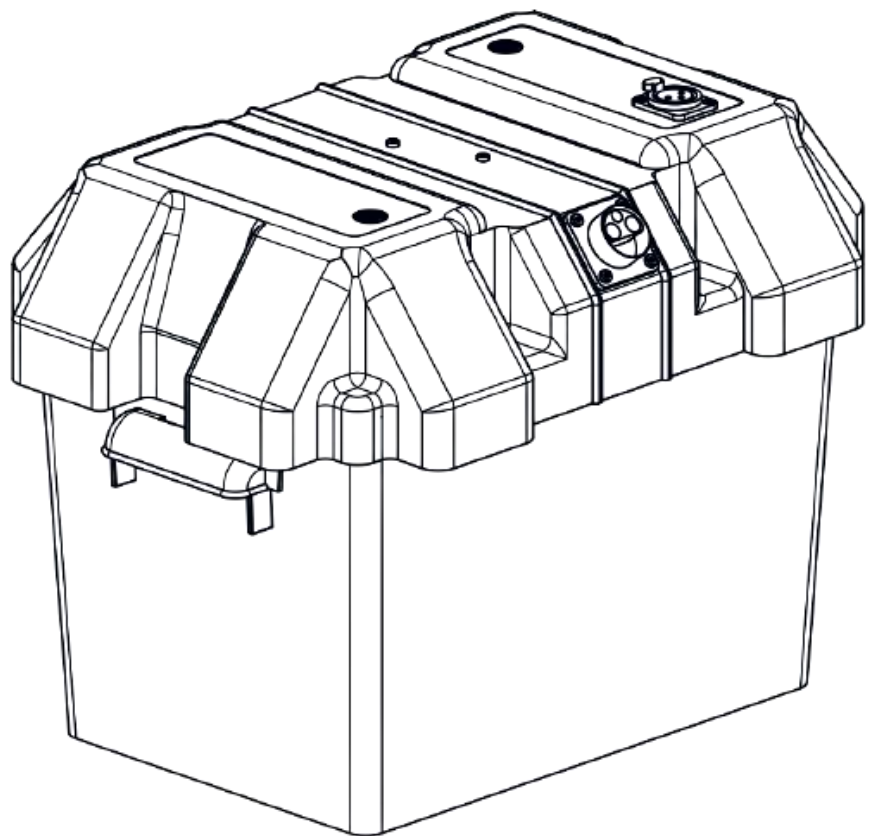

Battery package



Description

Battery box including two batteries to run control box and lifting column with 24V. Fuse included for safe usage. Charged with PB-120P-27C charger (bought separately). DIN9680 cable not included (bought separately).

Technical data

Product name	25626-24-30-1
Type	Battery box
Voltage	24V
Capacity	30Ah
Fuse	30A (+ one spare)
Dimensions	370x270x270mm
Weight	17kg
Connector A (on top)	XLR-Kontakt 3-pol (charger)
Connector B (on slope)	3-pin DIN9680 (24V power)

Technical drawing

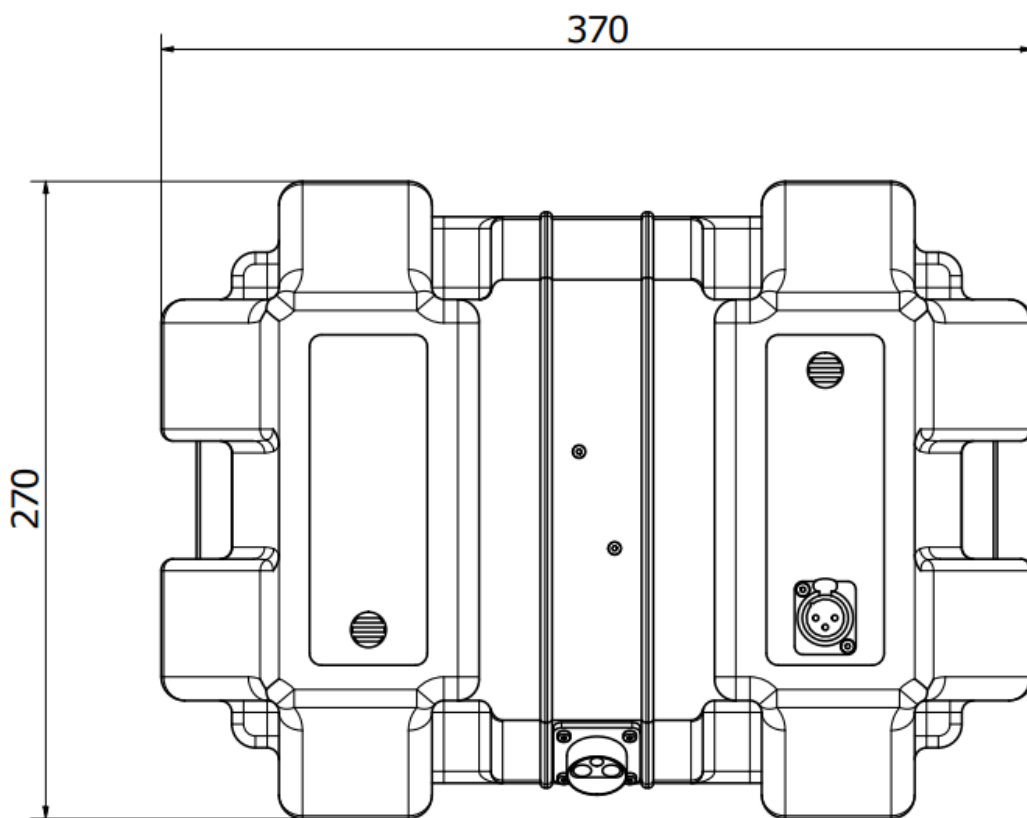
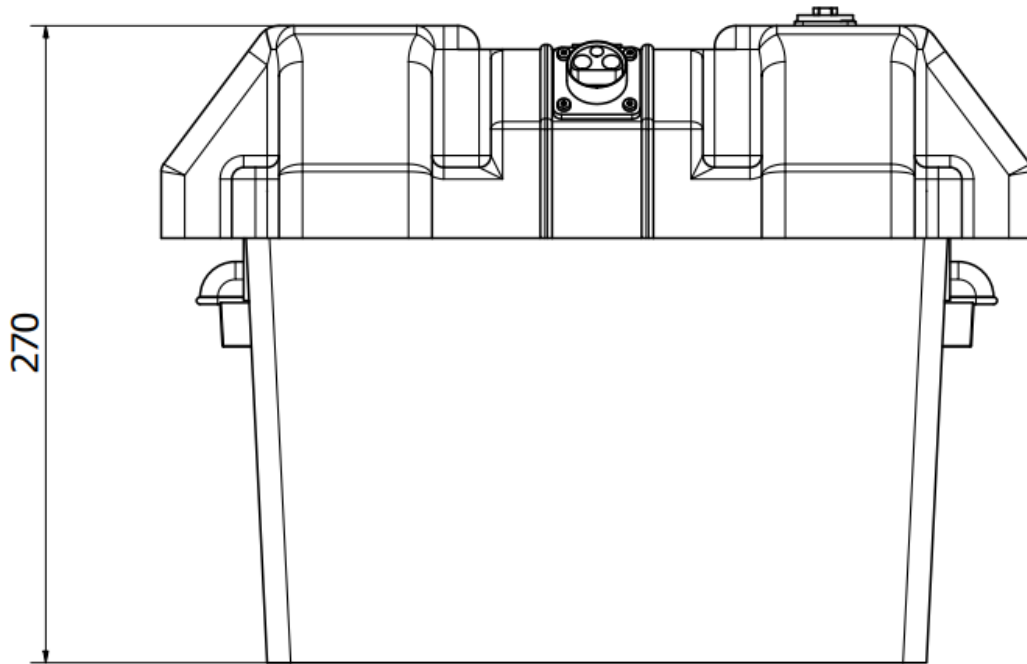

Charger

Description

Charger to charge the 24V battery package. Power cable bought separately.

Technical data

Product name	PB-120P-27C
Type	Charger
DC Voltage	27,6V
LED indicator	Load $46\% \pm 10\% \uparrow$: GREEN / $46\% \pm 10\% \downarrow$: RED
Dimensions	183x97x49mm
Connector A	Power plug (EU/US)
Connector B	XLR-Kontakt 3-pol (charger)
Standard	EN61000-4-2,3,4,5,6,8,11; EN50204, EN55024, EN55022



Technical drawing

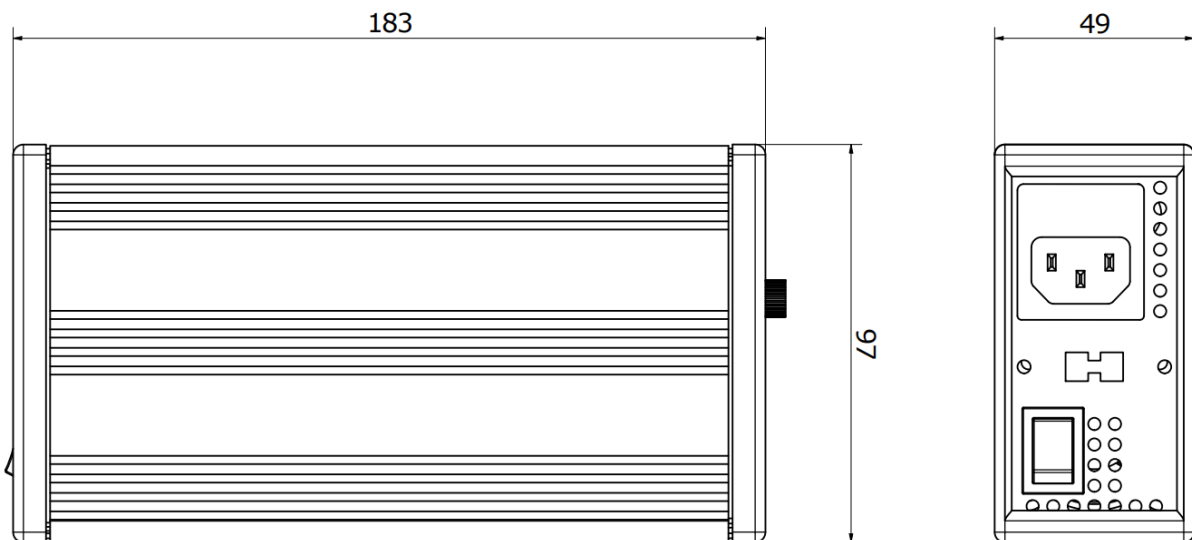

X2 Technology – The Customizer

Before use of products, see general terms & conditions and operating manuals. Lifetime and suitability are depending on application and must therefore be tested by each user. Specifications subject to change without prior notice. All components in this datasheet are property of X2 Technology and may therefore not be used without permission.

Copyright © X2 Technology 2021.07.

Phoenix Mecano AB



+46 470 717950



info@x2technology.se



www.x2technology.se



Made in Sweden



X2 TECHNOLOGY

A Phoenix Mecano Brand